

PrimeX-LV

PV 10KBA-L Quick Installation Guide

Version: 1.0

Doc. No.: PT-Q-231C01

Date: 2024/4/16











© Copyright 2023 Senergy Limited. All rights reserved. Specifications are subject to change without prior notice. Senergy Limited does not accept any responsibility whatsoever for potential errors or possible lack of information in this document.

Before installation, Please read this guide.

1. Read this guide carefully before installation to understand product features and safety precautions.
2. Installers should be well trained to fully understand grid-connected photovoltaic power systems and national/regional standards.
3. Installers must use insulated tools and wear safety equipment.
4. As required by local regulations, an overcurrent protection and isolation device that operates both positive and negative conductors simultaneously is required between inverter and battery system and also between parallel batteries. The cable needs to be prepared by the installer, cable specification: 35mm² / 2 AWG, cable terminal model: E35-16.
5. Before installation, ensure that battery pack is switched off, and open any associated circuit breakers and disconnect switches.

1 Product Packing List

Item Name	ID	Details	Quantity	Image	Notes
Battery	A	PV 10KBA-L 550x165x867 mm 21.65x6.50x31.21 in	1		
Output Cable	B	Positive: red plug, 35 mm ² / 2 AWG, L:1.5 m (59.06 in) to SC50-10 ring terminal Negative: black plug, 35 mm ² / 2 AWG, L:1.5 m (59.06 in) to SC50-10 ring terminal	2		Continuous flow capacity: 160 A
	C	Ground cable yellow & green/L:1 m (39.37 in)/ double OT M6	1		
Communication cable	D	Standard network cable black/L:1.5 m (59.06 in)/Double RJ45 Plug	1		
Back Plate	E	-	1		
Expansion Screw	G	M8*80 mm	4		
Screw	H	M5*16 mm	2		
Mounting Positioning Board	I	-	1		
RJ45 Water-proof Wiring Terminal	J	-	3		

2 Installation environment requirements

1. Ensure that the equipment is installed in a dry and well-ventilated environment.
2. The installation position must be away from direct sunlight and rain.
3. The installation position must be far away from fire sources
4. The installation position must be far away from water sources such as taps, sewer pipes, and sprinklers to prevent water seepage.
5. Do not expose the equipment to flammable or explosive gas or smoke.
6. Humidity:5%~95%RH (non-condensing);Operating temperature: -15°C~+55°C.
7. If it is to be installed indoors, it needs to be installed in a relatively open, safe, dry, and well ventilated indoor space, but it is necessary to ensure smooth air circulation in the installation location, such as a garage, balcony, corridor, or wall corner.

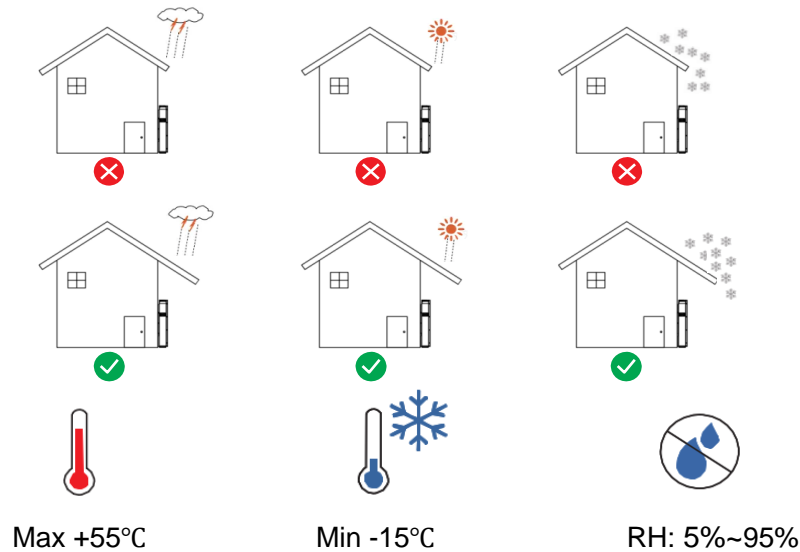

3 Product Appearance

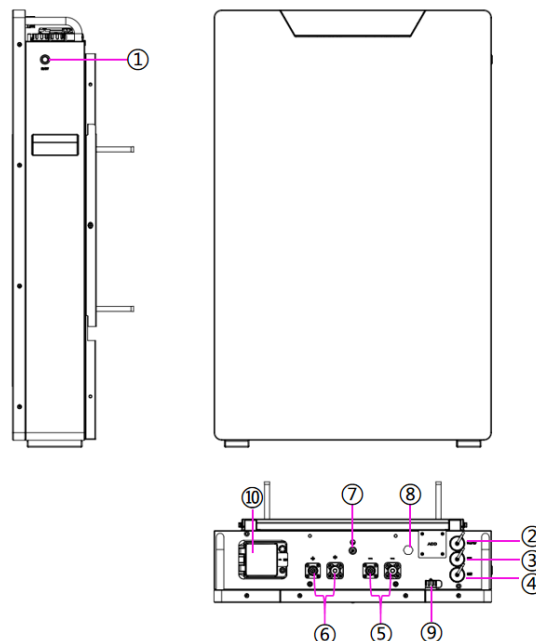

Number	Name	Details	Notes
1	Power Switch		Red light: ALM, Blue light: RUN
2	INVERTER	RJ45	CAN communication to the inverter
3	LINK IN	RJ45	Internal RS485 communication between batteries

4	LINK OUT	RJ45	Internal RS485 communication between batteries
5	Port Negative x2	Black, PSR8XAB	Black cable 35 mm ² / 2 AWG, cable plug model: PSRP8XA50
6	Port Positive x2	Red, PSR8XBB	Red cable 35 mm ² / 2 AWG, cable plug model: PSRP8XB50
7	GND	M6	Yellow-Green, 10 AWG
8	Breather Valve		
9	WIFI Socket		WiFi stick not selectable
10	125 A DC Breaker		

RJ45 Port Pin Definition

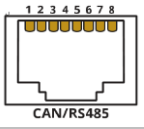
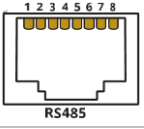
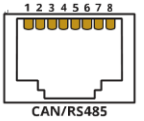
View	Item	Description	1	2	3	4	5	6	7	8
	2	INVERTER	-	RS485-A	RS485-B	CAN-H	CAN-L	GND	-	-
	3	LINK IN	-	BMS-RS485-A	BMS-RS485-B	DI+	DI-	-	BMS-CAN-H	BMS-CAN-L
	4	LINK OUT	-	BMS-RS485-A	BMS-RS485-B	DO+	DO-	-	BMS-CAN-H	BMS-CAN-L

4 Installation

4.1 Battery Installation

4.1.1

1. Measure the mounting space (position a cardboard the same size as the battery).
2. Mark the fixed position with the "mounting locating plate (I)".

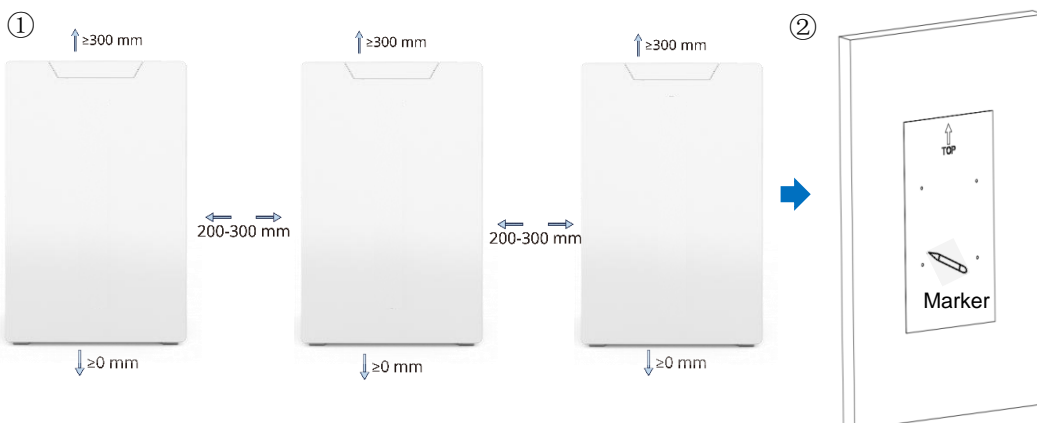

⚠ Note: Ensure that the mounting locating plate is level with the floor.

4.1.2

1. Use an impact electric drill to drill holes in the concrete or stone (fireproof) wall, the drilling depth is between 80mm and 85mm: The drill diameter is 12 mm.
2. Tighten the expansion bolt (G) slightly and put it into the hole. Knock the expansion bolt with a rubber hammer until all the expansion pipes enter into the hole.
3. Pre-tighten the expansion bolt.
4. Screw out the bolts and remove the spring washer and flat washer.

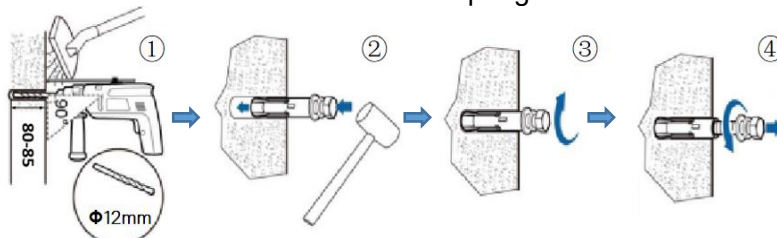

⚠ Note: Expansion bolts are mainly used for solid brick-concrete walls and concrete floors. If you choose other types of walls and floors, ensure that they meet the load-bearing requirements and select the bolts yourself.

4.1.3

1. Fix the "Back Plate (E)" to the wall.
2. Hang the battery on the bracket according to the picture below.
3. Secure the PACK from the side using screws (H).

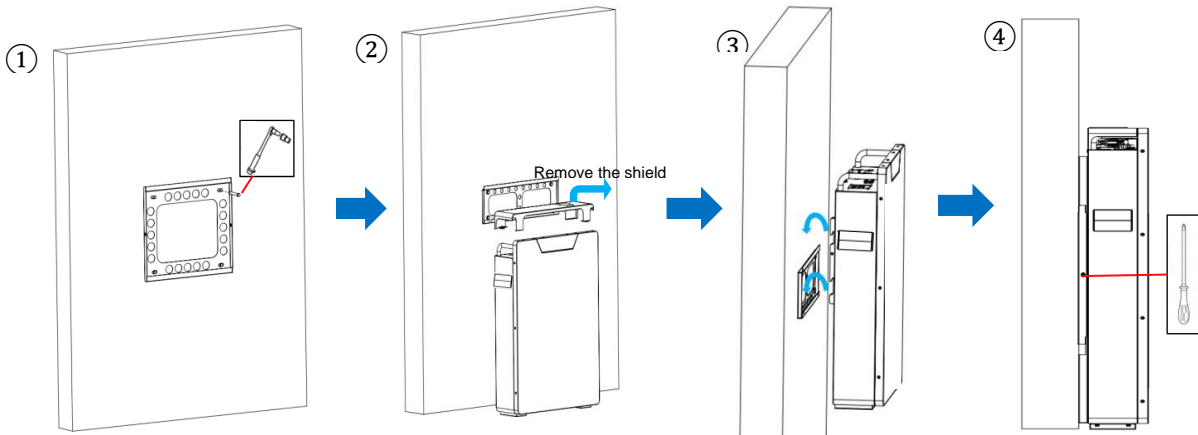

4.2 Single Unit Connection

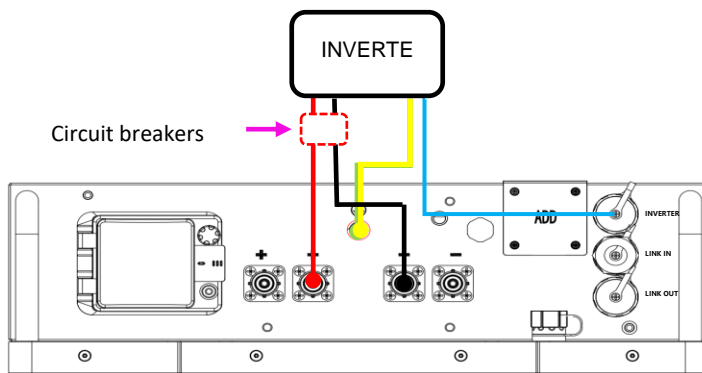

⚠ Note: Before electrical connection, ensure that the circuit breaker/power switch of the battery and all switches connected to the energy storage are in the OFF state. Otherwise, electric shock may occur.

1. The rated output power of the cable connection is 3 kW; SOC>70% The output power is 5 kW.
2. Install circuit breakers based on local regulations.

4.2.1 Ground Connection

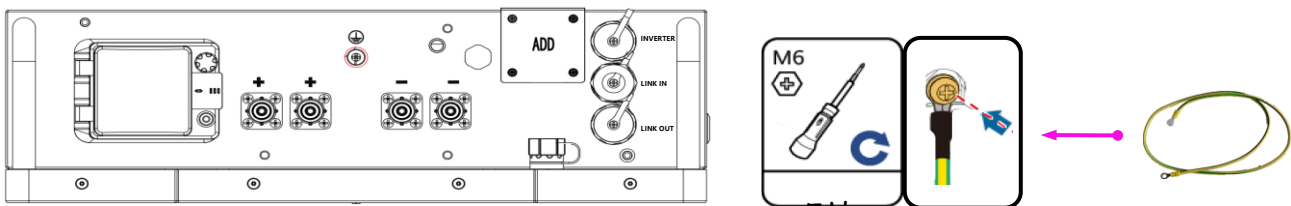

4.2.2 Communication Connection

1. Route the communications cable through the RJ45 cable cover (J) .
2. Connect the communications cable to the RJ45 port (marked "Inverter").
3. Tighten the RJ45 cable cover.
4. Connect the other end of the communication cable to the inverter.

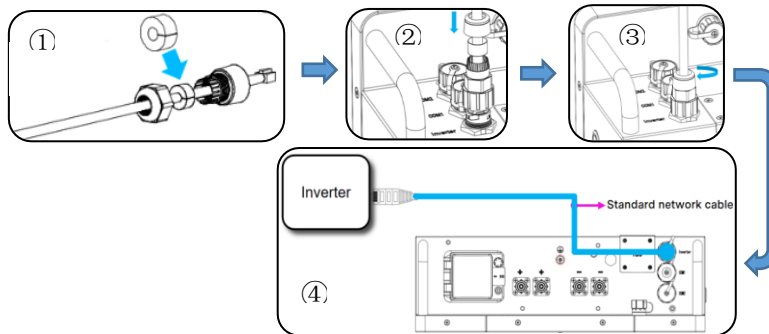

4.2.3 Power Cable Connection

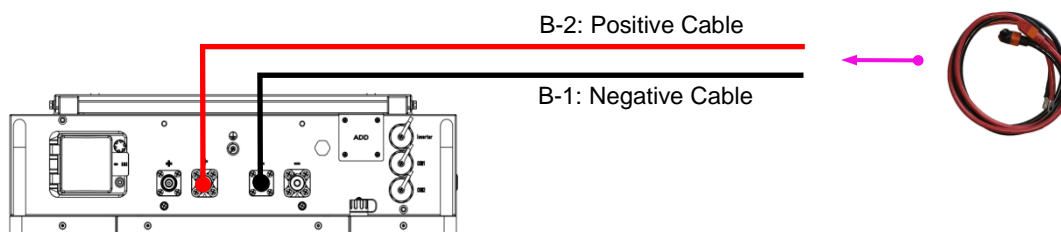

4.2.4 Activate Battery

1. Turn on the circuit breaker while the power switch is off.
2. Turn on Power Switch to start battery. After five seconds, a blue light flashes to indicate normal operation.
3. Cover with the front cover after checking.

NOTE:

State	Standby	Charge	Discharge	Failure
Light	○	○	○	○
Remarks	Light 0.25 S / Lights out 3.75 S	Light 0.5 S / Lights out 0.5 S	Lights stay on	Flicker/persist
	When the battery starts up, the red and blue lights alternately flash, indicating that the battery self-test is normal			

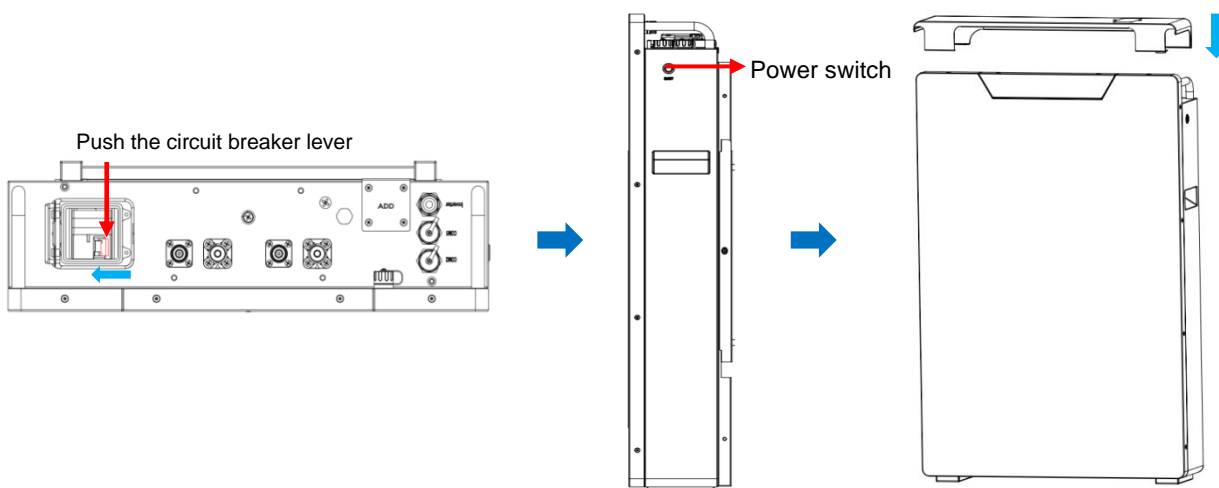

The order of turning off the battery is opposite to activating the battery

4.3 Multi-Unit Connection with Bus-Bars (3-Unit Example)

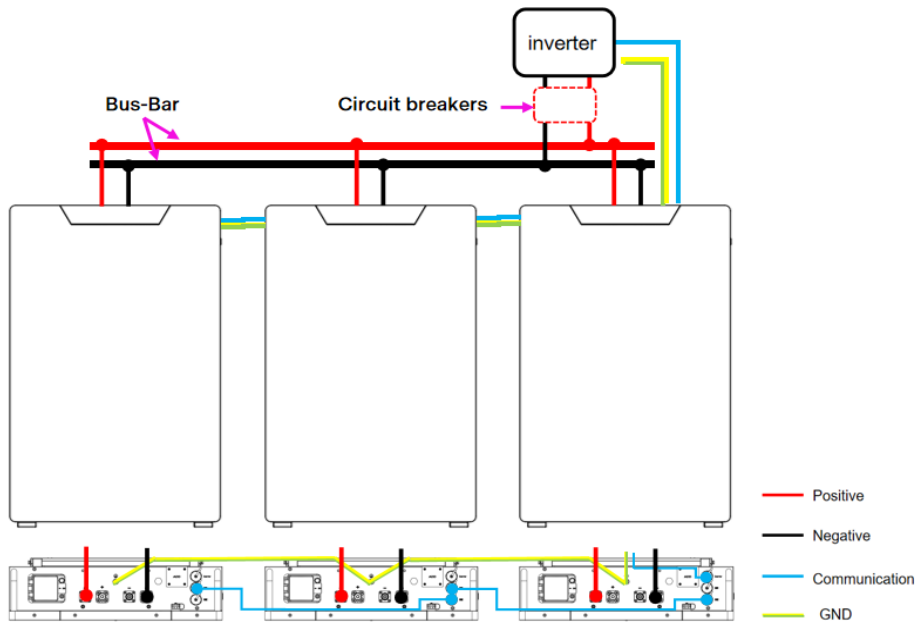

1.The method of cable connection with a bus-bar will output a power of $3 \times 6 \text{ kW} = 18 \text{ kW}$.

2.Max. number of parallel units: 16. Note that the max. recommended charge and discharge power is 96 kW continuous and 130 kW peak.

3.Install circuit breakers based on local regulations.

4.3.1 Ground Connection

Please follow step 1.

4.3.2 Parallel communication

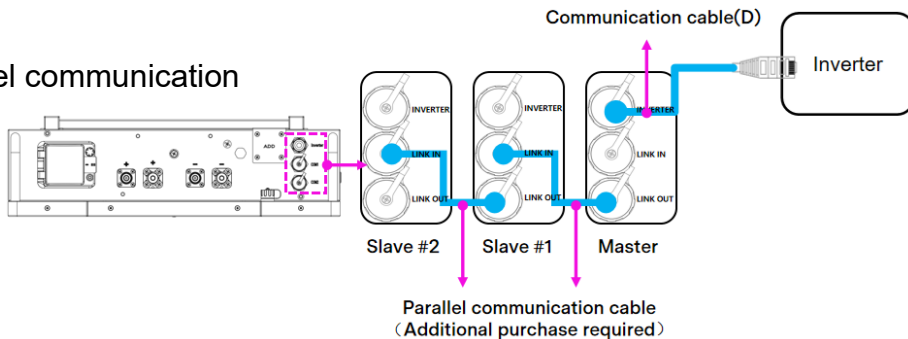

For details about communication wiring follow step 4.2.2.

4.3.3 Power Cable Connection

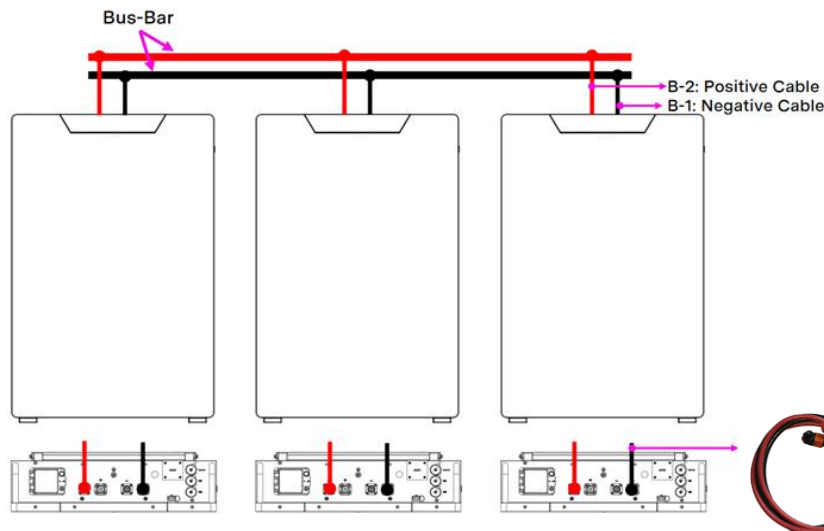

4.3.4 Activate Battery Bank

Please follow step 4.2.4. Make sure all breakers are turned on before pressing the power switches on all batteries.

4.4 Multi-Unit Connection without Bus-Bars (3-Unit Example)

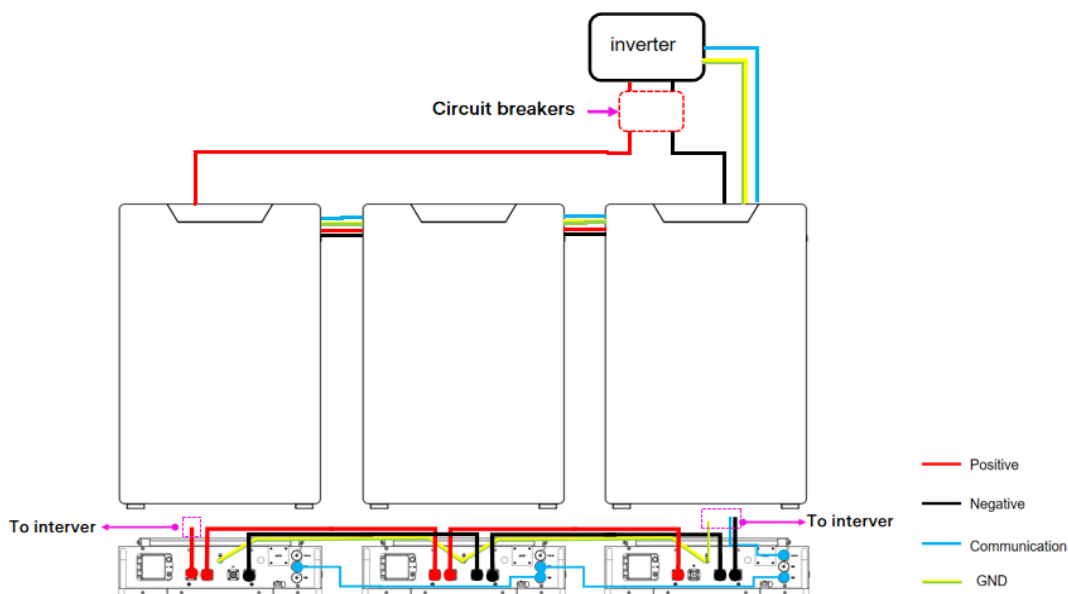

1. This wiring method will allow a max. power output of 6 kW continuous, limited by the wiring and connectors. Make sure the connected inverter does not exceed 6 kW/120 A continuous during both charge and discharge.

2. Install circuit breakers based on local regulations.

4.4.1 Ground Connection

Please follow step 1.

4.4.2 Communication Connection

Please follow step 4.2.2.

4.4.3 Power Cable Connection

Note: Parallel cable needs to be purchased extra.

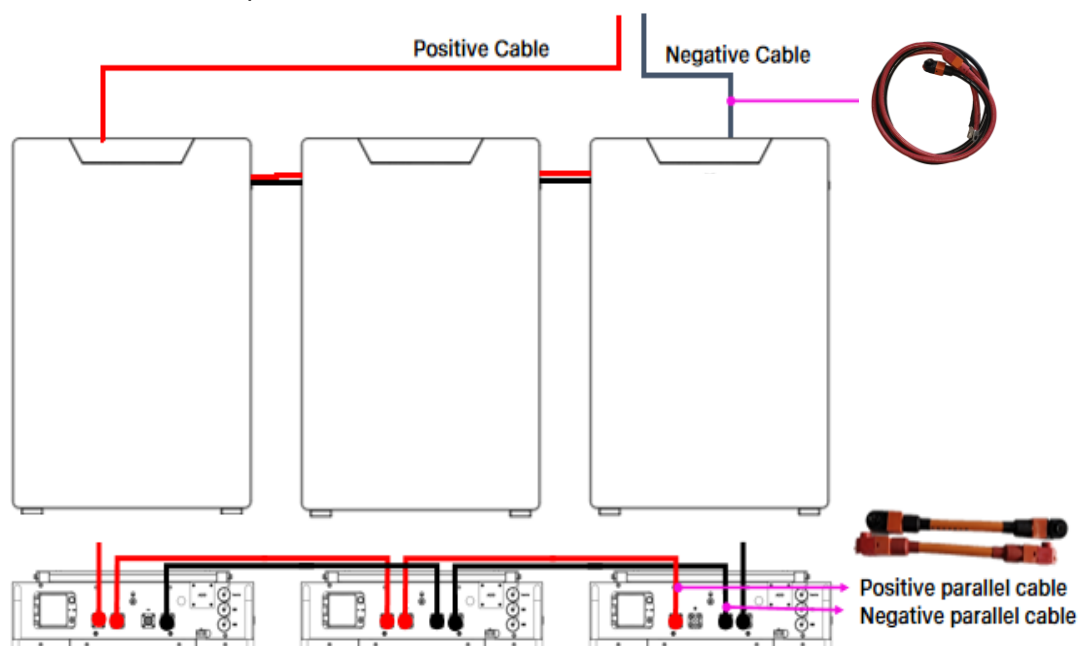

4.4.4 Activate Battery Bank

Please follow step 4.2.4. Make sure all breakers are turned on before pressing the power switches on all batteries.

5 Manufacturing Cables When Required

5.1 Power Cable

5.1.1 Material List (plug components may be purchased separately from supplier)



Plug sub assembly



Cable sealing ring



Plug protection cover

Steps:

Procedure	Schematic picture
1.Route the cable through the isolation cable sealing ring and Plug protection cover.	
2.Remove 13mm of insulation at end of cable.	
3.The red plug is used for the positive, and the black is for the negative power cable. The end of the cable is crimped at the terminal using a crimping clamp.	
4.Tighten the isolation cap and plug contact.	
5.Put the positive and negative plug on to the system and tighten them.	
6.Use isolation cap for unused DC plug.	

5.2 Communication Cable

5.2.1 Battery to Battery Communication Cable

Pin definition as below, alternatively a standard straight CAT 5 Ethernet cable can be used.



5.2.2 Battery to Inverter Communication Cable

Pin definition as below, alternatively a standard straight CAT 5 Ethernet cable can be used., For the inverter end pin definition, see the inverter specification.



6 Other

Install an isolation device (i.e. a circuit breaker) between the inverter and the battery system to run both positive and negative conductor overcurrent protection. The steps for installing isolation devices (i.e. circuit breakers) are as follows:

1. Use E35-16 terminals to connect the wiring harness to the isolation device.
2. Insert the wiring harness terminal into the connection port of the isolation device, and distinguish the positive and negative terminals of the isolation device (see the isolation device specifications for details);
3. Tighten the wiring harness terminal with screws to secure it.

Note: During installation, please turn off the battery power switch and check whether the power is off. The cable from the circuit breaker to the inverter is provided by the installation personnel. (Please refer to the Product Packaging List for cable specifications).

Circuit breaker selection: DC60V, xA ($100 * n * 1.2 = x$ (n is the number of batteries, x is the calculated value))